



Solis 4G Three Phase Inverter

(5-10kW) **Installation and Operation Manual**

Ver 1.1

Ningbo Ginlong Technologies Co., Ltd.

No. 57 Jintong Road, Binhai Industrial Park, Xiangshan, Ningbo,
Zhejiang, 315712, P.R.China.

Tel: +86 (0)574 6578 1806

Fax: +86 (0)574 6578 1606

Email: info@ginlong.com

Web: www.ginlong.com

If you encounter any problem on the inverter, please find out the inverter S/N
and contact us, we will try to respond to your question ASAP.



Ginlong (Ningbo) Technologies Co., Ltd.

1. Introduction	2
1.1 Product Description	2
1.2 Packaging	3
2. Safety Instructions	4
2.1 Safety Symbols	4
2.2 General Safety Instructions	4
2.3 Notice For Use	5
3. Overview	6
3.1 Front Panel Display	6
3.2 LED Status Indicator Lights	6
3.3 Keypad	6
3.4 LCD	6
4. Product handling and storage	7
4.1 Product handling	7
4.2 Product Storage	8
5. Installation	9
5.1 Select Location for the Inverter	9
5.2 Mounting the Inverter	11
5.3 Electrical Connections	13
6. Start & Stop	21
6.1 Start the Inverter	21
6.2 Stop the Inverter	21
7. Operation	22
7.1 Main Menu	22
7.2 Information	22
7.3 Settings	24
7.4 Advanced Info.	24
7.5 Advanced Settings	27
8. Maintenance	31
9. Troubleshooting	31
10. Specifications	34

1. Introduction

1.1 Product Description

Solis 4G three phase inverters integrate DRM and backflow power control function, that could suitable for smart grid requirement.

Three phase 4G series inverter contain 6 models which are listed below:

Solis-3P5K-4G, Solis-3P6K-4G, Solis-3P8K-4G, Solis-3P9K-4G, Solis-3P10K-4G

Solis-3P5K-4G-LV

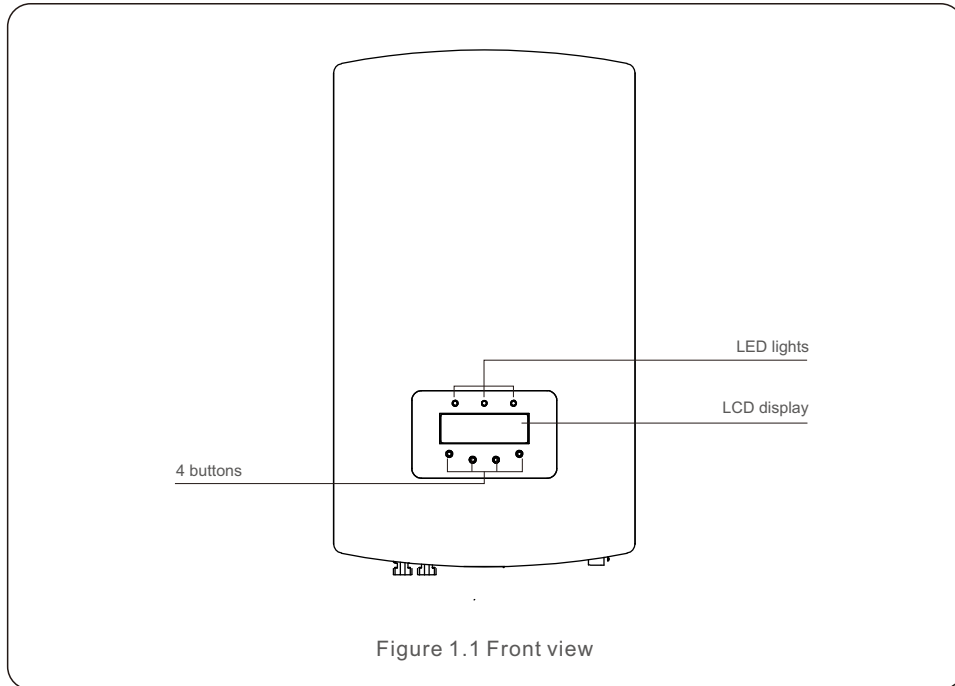

Figure 1.1 Front view

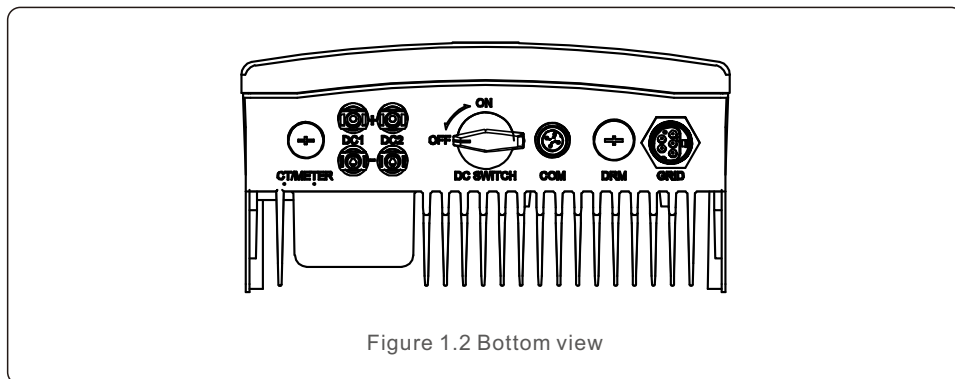
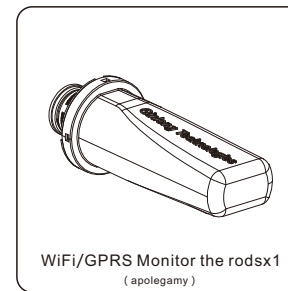
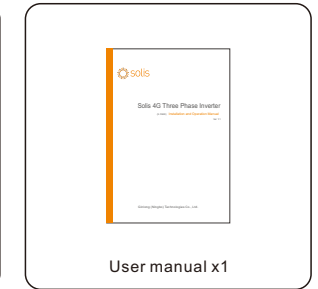
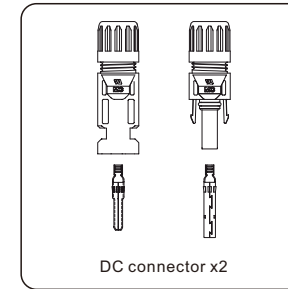
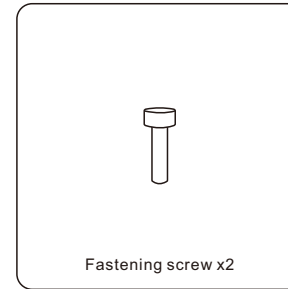
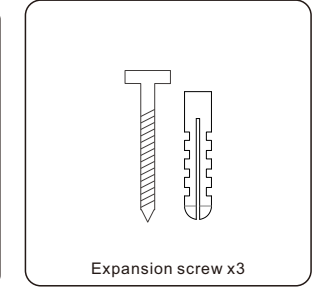
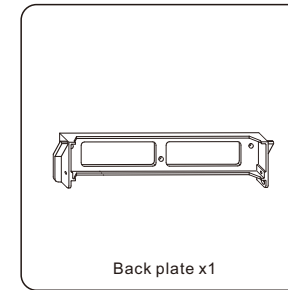
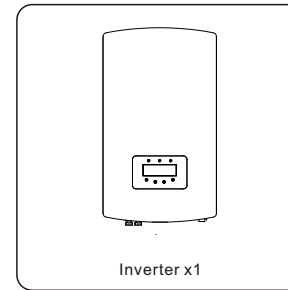

Figure 1.2 Bottom view

1. Introduction

1.2 Packaging

When you receive the inverter, please ensure that all the parts listed below are included:



If anything is missing, please contact your local Solis distributor.

2. Safety Instructions

2.1 Safety Symbols

Safety symbols used in this manual, which highlight potential safety risks and important safety information, are listed as follows:



WARNING:

WARNING symbol indicates important safety instructions, which if not correctly followed, could result in serious injury or death.



NOTE:

NOTE symbol indicates important safety instructions, which if not correctly followed, could result in some damage or the destruction of the inverter.



CAUTION:

CAUTION, RISK OF ELECTRIC SHOCK symbol indicates important safety instructions, which if not correctly followed, could result in electric shock.



CAUTION:

CAUTION, HOT SURFACE symbol indicates safety instructions, which if not correctly followed, could result in burns.

2.2 General Safety Instructions



WARNING:

Please don't connect PV array positive(+) or negative(-) to ground, it could cause serious damage to the inverter.



WARNING:

Electrical installations must be done in accordance with the local and national electrical safety standards.



WARNING:

To reduce the risk of fire, over-current protective devices (OCPD) are required for circuits connected to the Inverter.

The DC OCPD shall be installed per local requirements. All photovoltaic source and output circuit conductors shall have disconnects that comply with the NEC Article 690, Part II. All Solis three phase inverters feature an integrated DC switch.



CAUTION:

Risk of electric shock. Do not remove cover. There is no user serviceable parts inside. Refer servicing to qualified and accredited service technicians.

2. Safety Instructions



CAUTION:

The PV array (Solar panels) supplies a DC voltage when they are exposed to sunlight.



CAUTION:

Risk of electric shock from energy stored in capacitors of the Inverter. Do not remove cover for 5 minutes after disconnecting all power sources (service technician only). Warranty may be voided if the cover is removed without unauthorized.



CAUTION:

The surface temperature of the inverter can exceed 75°C (167F). To avoid risk of burns, DO NOT touch the surface when inverter is operating. The inverter must be installed out of reach of children.

2.3 Notice For Use

The inverter has been constructed according to the applicable safety and technical guidelines. Use the inverter in installations that meet the following specifications only:

1. Permanent installation is required.
2. The electrical installation must meet all the applicable regulations and standards.
3. The inverter must be installed according to the instructions stated in this manual.
4. The inverter must be installed according to the correct technical specifications.
5. To startup the inverter, the Grid Supply Main Switch (AC) must be switched on, before the solar panel's DC isolator shall be switched on. To stop the inverter, the Grid Supply Main Switch (AC) must be switched off before the solar panel's DC isolator shall be switched off.

3. Overview

3.1 Front Panel Display

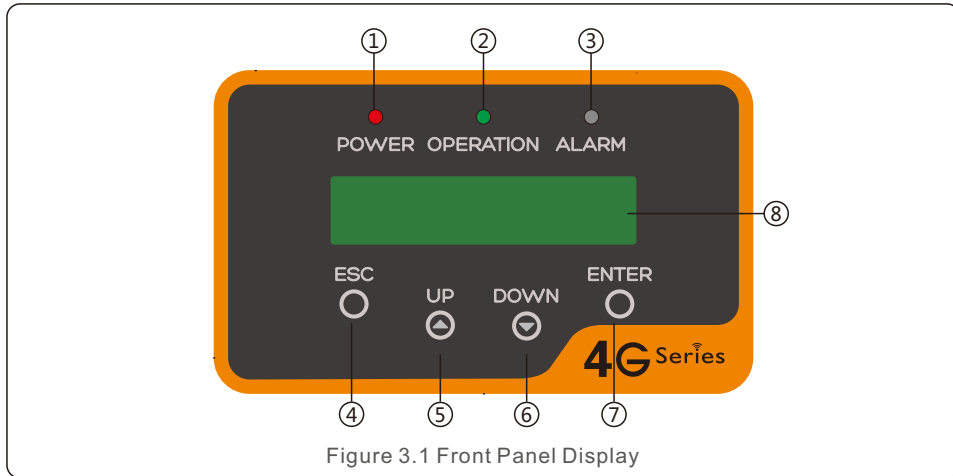

Figure 3.1 Front Panel Display

3.2 LED Status Indicator Lights

	Light	Status	Description
①	● POWER	ON	The inverter can detect DC power.
		OFF	No DC power or low DC power.
②	● OPERATION	ON	The inverter is operating properly.
		OFF	The inverter has stopped to supply power.
		FLASHING	The inverter is initializing.
③	● ALARM	ON	Alarm or fault condition is detected.
		OFF	The inverter is operating properly.

Table 3.1 Status Indicator Lights

3.3 Keypad

There are four keys in the front panel of the Inverter(from left to right): ESC, UP, DOWN and ENTER keys. The keypad is used for:

- Scrolling through the displayed options (the UP and DOWN keys);
- Access to modify the adjustable settings (the ESC and ENTER keys).

3.4 LCD

The two-line Liquid Crystal Display (LCD) is located on the front panel of the Inverter, which shows the following information:

- Inverter operation status and data;
- Service messages for operator;
- Alarm messages and fault indications.

4. Product handling and storage

4.1 Product handling

Please review the instruction below for handling the inverter:

1 The red circles below denote cutouts on the product package.

Push in the cutouts to form handles for moving the inverter (see Figure 4.1).

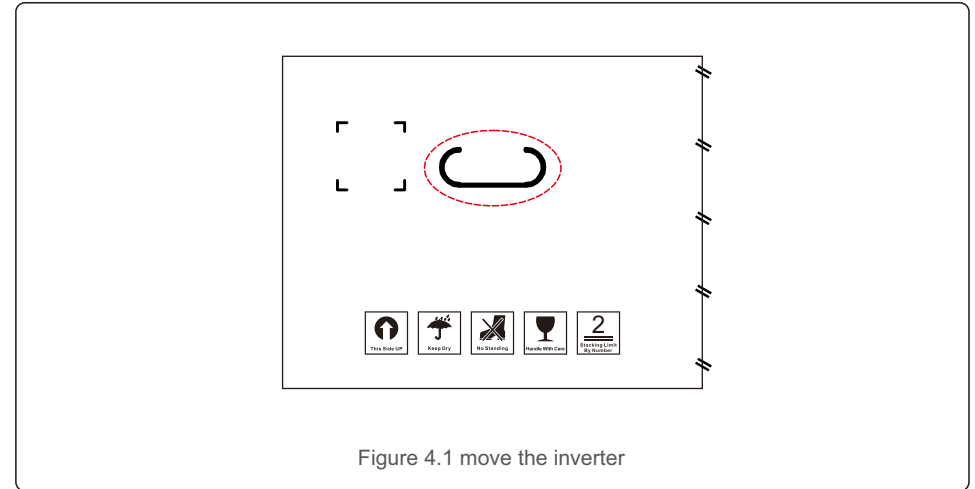

Figure 4.1 move the inverter

2. Open the carton, then handle both sides of inverter through the area denoted dotted line. (see figure 4.2).

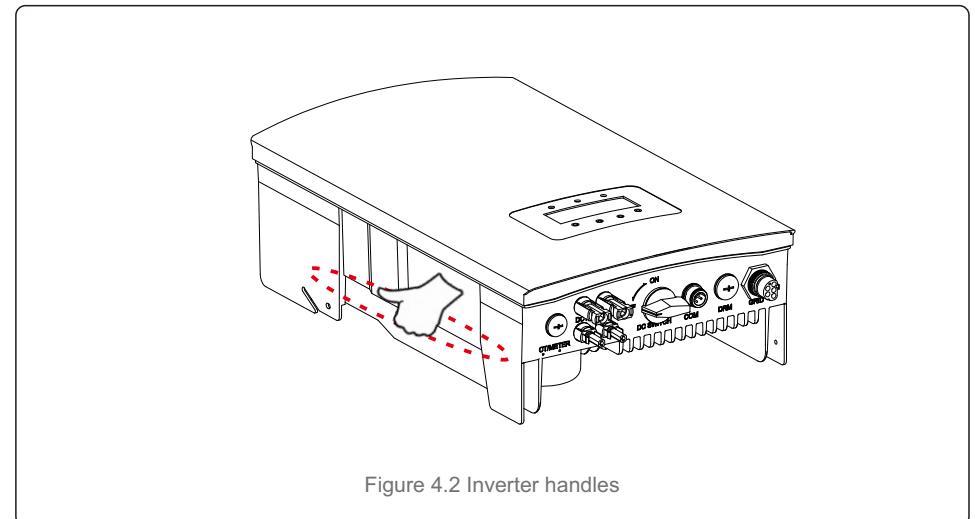

Figure 4.2 Inverter handles

4. Product handing and storage

4.2 Product Storage

If the inverter is not to be installed immediately, storage instructions and environmental conditions are below:

- Use the original box to repackage the inverter, seal with adhesive tape with the desiccant inside the box.
- Store the inverter(s) in a clean and dry place, free of dust and dirt.
- Storage temperature must be between -25 and 60C and the humidity should be between 0 and 100% non-condensing .
- Stack no more than four (4) inverters high.
- Keep box(es) away from corrosive materials to avoid damage to the inverter enclosure.
- Inspect packaging regularly. If packaging is damaged (wet, pest damage, etc), repackage the inverter immediately.
- Store the inverter(s) on a flat, hard surface – not inclined or upside down.
- After long-term storage, the inverter needs to be fully examined and tested by qualified service or technical personnel before using.
- Restarting after a long period of non-use requires the equipment to be inspected and, in some cases, the removal of oxidation and dust that has settled inside the equipment will be required.

5. Installation

5.1 Select a Location for the Inverter

To select a location for the inverter, the following criteria should be considered:

- Do not install in small closed spaces where air can not circulate freely. To avoid overheating, always make sure the flow of air around the inverter is not blocked.
- Exposure to direct sunlight will increase the operational temperature of the inverter and may cause output power limiting. Ginlong recommends inverter installed to avoid direct sunlight or raining.
- To avoid over heating ambient air temperature must be considered when choosing the inverter installation location. Ginlong recommends using a sun shade minimizing direct sunlight when the ambient air temperature around the unit exceeds 104°F/40°C.

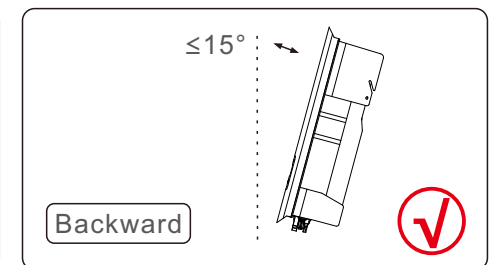
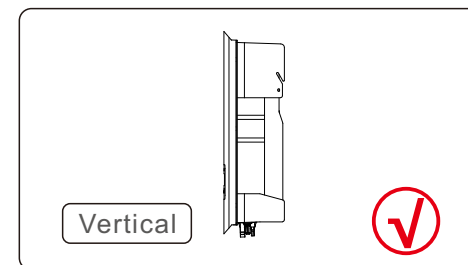
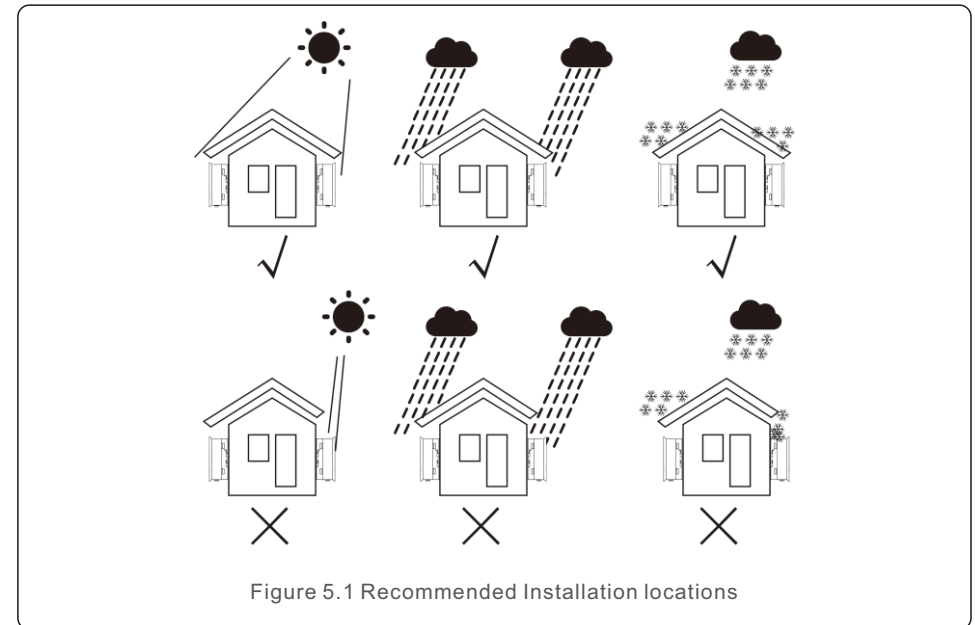

5. Installation

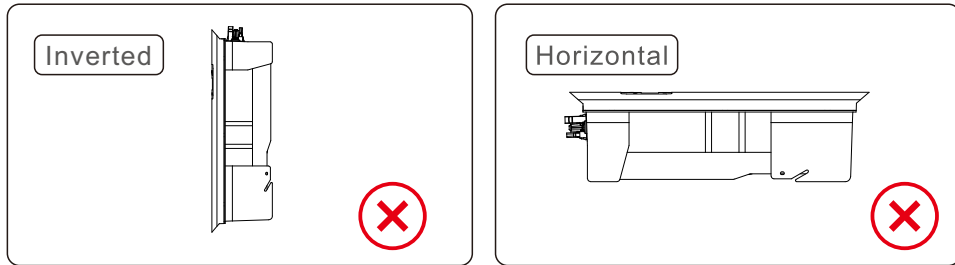

- The visibility of LED status indicator lights and LCD should be considered.
- Install vertically (+/- 5°) or tilted backward (<=15°).
- Don't mount inverter on the tilted forward wall.
- Don't mount inverter on the horizontal.

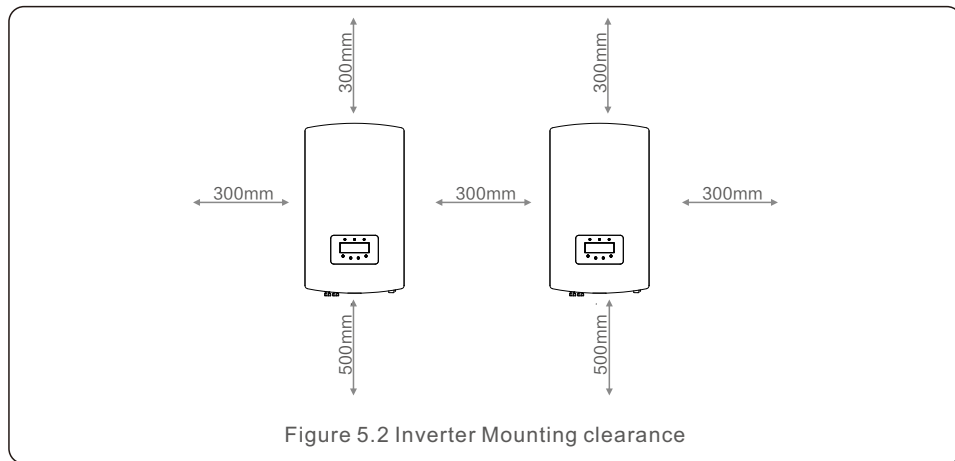

Figure 5.2 Inverter Mounting clearance

- Temperature of inverter heat sinker might 167°F/75°C.
- Inverter is designed for working extreme environment, operation temperature range: -15°F/25°C~149°F/65°C.
- When 1 or more inverters are installed in one location, a minimum 12inches clearance should be kept between each inverter or other object. The bottom of the inverter should be 20inches clearance to the ground.



NOTE:

Nothing should be stored on or placed against the inverter.

5. Installation

5.2 Mounting the Inverter

Dimensions of mounting bracket:

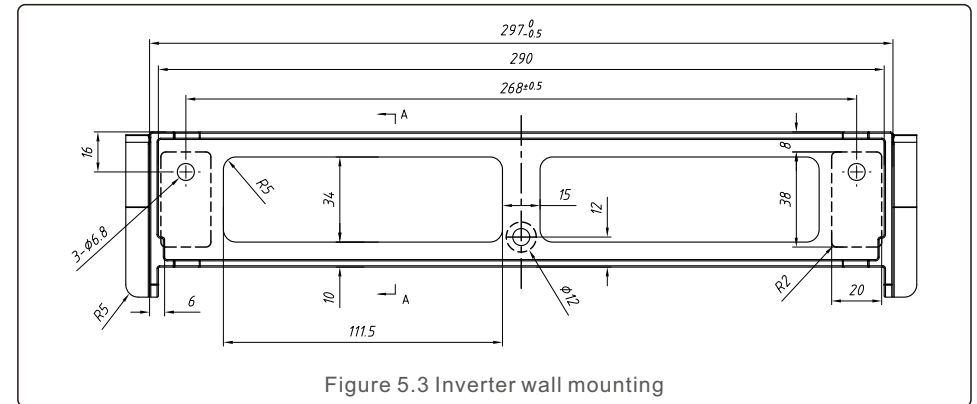

Figure 5.3 Inverter wall mounting

Refer to figure 5.4 and figure 5.5. Inverter shall be mounted vertically. The steps to mount the inverter are listed below.

1. Refer to Figure 5.4, the holes for expansion bolt based on the hole diameter of bracket (ST6.3*60 cross recessed hexagon head tapping screws, HJ0108 10*50mm fished expandable tubular), using the percussion drilling with the 10mm drill need to stay vertically on the wall. And the drill hole must be vertically on the wall. And all drill holes' depth is 60mm.

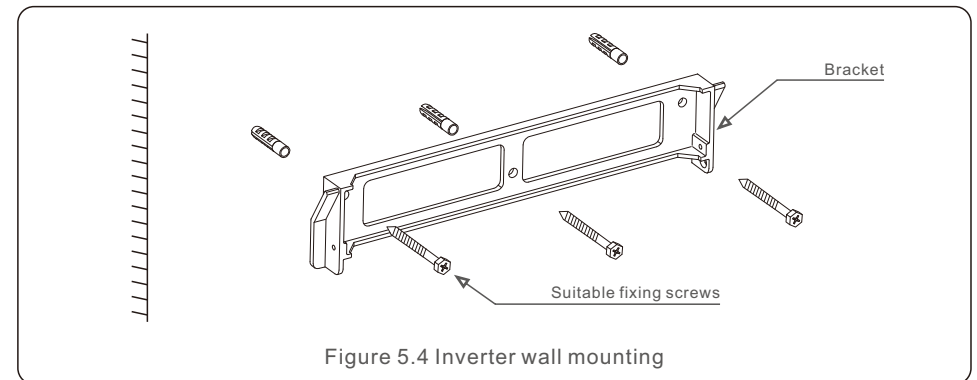

Figure 5.4 Inverter wall mounting

2. Make sure the bracket is horizontal. And the mounting holes (in Figure 5.4) are marked correctly. Drill the holes into wall at your marks.
3. Use the suitable expansion screws to fix the bracket on the wall.



WARNING:

The inverter must be mounted vertically.

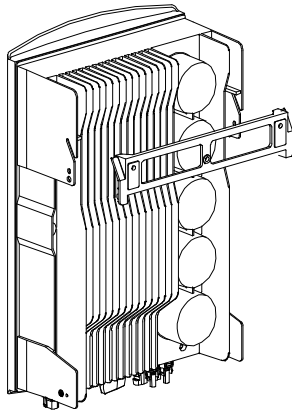

Figure 5.5 Install the inverter

4. Lift the inverter and hang it on the bracket, and fixing both sides of inverter with locking screws (accessories).

Locking screws

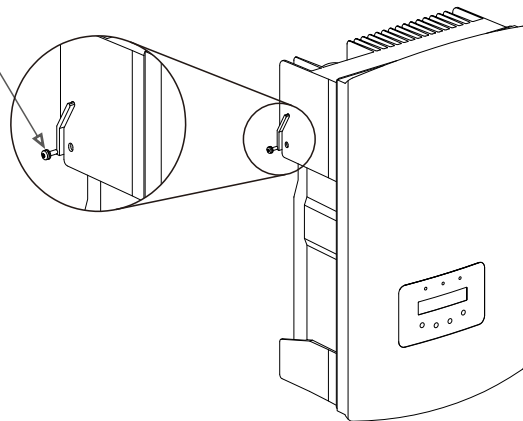

Figure 5.6 Fixed the inverter

5. Anti-theft lock mount(optional)

Anti-theft lock(User-supplied) function is that inverter is fixed in bracket in case theft. The lock is selected by 5mm(the keyhole diameter), and the lock of stainless steel is preferred.

Anti-theft lock

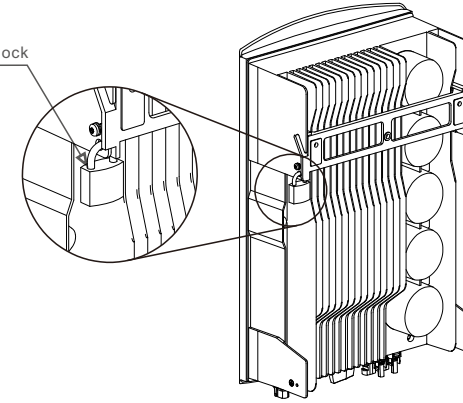

Figure 5.7 Install security lock

5.3 Electrical Connections

Inverter designs quick-connect terminal, so top cover needn't open during electrical connection. The sign meaning located the bottom of inverter, as shown below in table 5.1. All electrical connections are suit for the local or national standard.

+	Positive DC input terminal
-	Negative DC input terminal
DC 1	DC input terminal
DC 2	DC input terminal
DC SWITCH	Switch of DC input terminals
COM	RJ45 and terminal block for RS485 communication port
GRID	Connecting terminal of the Grid

Table 5.1 Electrical connection symbols

The electrical connection of the inverter must follow the steps listed below:

1. Switch the Grid Supply Main Switch (AC) OFF.
2. Switch the DC Isolator OFF.
3. Assemble PV input connector to the Inverter.

5. Installation

5.3.1 Grounding

Solis recommends 2 ground protection methods: Through grid terminal connection and external heat sink connection.

If AC terminal is used to connect ground, please refer to the contents of 5.3.2.

If the heat sink is used to connect the ground, please follow the steps below:

- 1) Prepare the grounding cable: recommend to use the $\geq 6\text{mm}^2$ outdoor copper-core cable.
- 2) Prepare OT terminals: M6.



Important:

For multiple inverters in parallel, all inverters should be connected to the same ground point to eliminate the possibility of a voltage potential existing between inverter grounds.

- 3) Strip the ground cable insulation to a suitable length (see Figure 5.8).

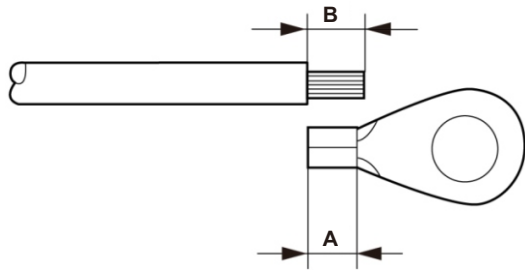

Figure 5.8 suitable length



Important:

B (insulation stripping length) is 2mm~3mm longer than A (OT cable terminal crimping area) 2mm~3mm.

- 4) Insert the stripped wire into the OT terminal crimping area and use the hydraulic clamp to crimp the terminal to the wire (see Figure 5.9).

5. Installation

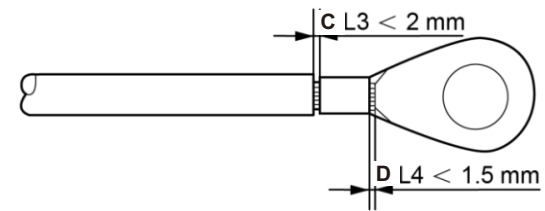

Figure 5.9 strip wire



Important:

After crimping the terminal to the wire, inspect the connection to ensure the terminal is solidly crimped to the wire.

- 5) Remove the screw from the heat sink ground point.
- 6) Connect the grounding cable to the grounding point on the heat sink, and tighten the grounding screw, Torque is 3Nm (see figure 5.10).

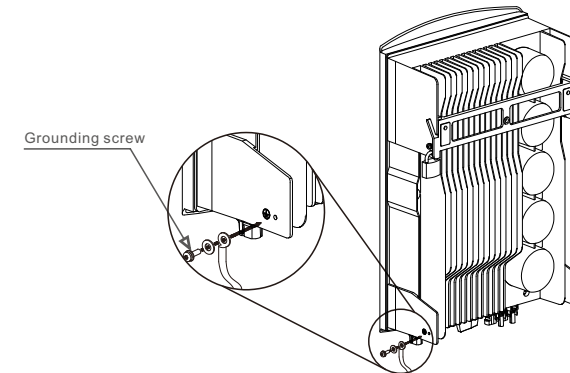

Figure 5.10 Fixed cable



Important:

For improving anti-corrosion performance, after ground cable installed, apply silicone or paint is preferred to protect.

5. Installation

5. Installation

5.3.2 Connect PV side of inverter



Before connecting inverter, please make sure the PV array open circuit voltage is within the limit of the inverter.



Before connection, please make sure the polarity of the output voltage of PV array matches the “DC+” and “DC-” symbols.



Before connecting inverter, please make sure the PV array open circuit voltage is within the limit of the inverter.

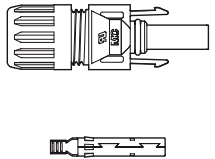

Figure 5.11 DC+ Connector

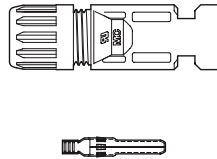

Figure 5.12 DC- Connector



Please use approved DC cable for PV system.

Cable type	Cross section (mm ²)	
	Range	Recommended value
Industry generic PV cable (model:PV1-F)	4.0~6.0 (12~10AWG)	4.0 (12AWG)

The steps to assemble the DC connectors are listed as follows:

1. Strip off the DC wire for about 7mm, Disassemble the connector cap nut. (see Figure 5.13)
2. Insert the wire into the connector cap nut and contact pin. (see Figure 5.14)
3. Crimp the contact pin to the wire using a proper wire crimper. (see Figure 5.15)
4. Insert metal connector into top of connector, and tighten nut with torque 2.5-3 Nm (see figure 5.16).

5. Measure PV voltage of DC input with multimeter, verify DC input cable polar (see figure 5.17), and ensure each string of PV voltage in range of inverter operation. Connect DC connector with inverter until hearing a slight clicking sound indicates connection succeed. (see figure 5.18)

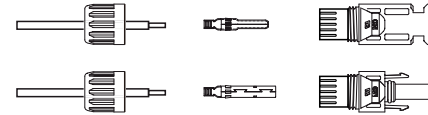

Figure 5.13 Disassemble the Connector Cap nut

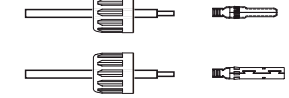

Figure 5.14 Insert the Wire into the Connector Cap nut and contact pin

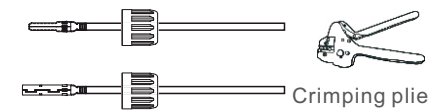

Figure 5.15 Crimp the contact pin to the wire

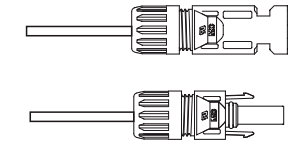

Figure 5.16 Connector with Cap nut Screwed on

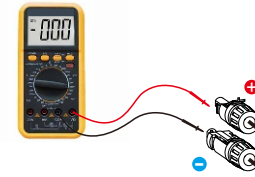

Figure 5.17 Multimeter measurement

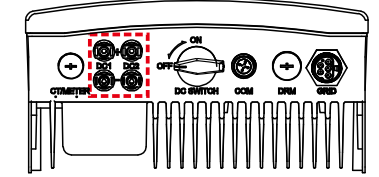

Figure 5.18 Connect the DC Connectors to the Inverter



WARNING:

If DC input wire reverses, please not operate DC switch, DC1 and DC2 instantly to avoid inverter damage.. Damage caused by this reason isn't covered by warranty.

Solution: Until reduced sun irradiance and PV voltage is below 0.5 A (mostly in evening), then put DC switch in “off” position, remove “+”, “-” connectors to reconnect wires.

5. Installation

5.3.3 Connect grid side of inverter

For all AC connections, 2.5 – 6 mm², 105°C cable is required to be used. Please make sure the resistance of cable is lower than 1.50hm. If the wire is longer than 20m, preferred to 6mm² cable.



Internal of AC connector signs "L1", "L2", "L3", "N" and "PE⊕" five connection ports (see Figure 5.20). Three live wires are connected the "L1", "L2" and "L3" terminals respectively; ground wire connects "PE⊕"; neutral wire connects "N" terminal:

Each inverter has a corresponding AC grid terminal connector. See figure 5.19.



Figure 5.19
AC Grid Terminal Connector

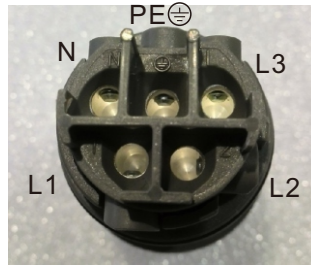

Figure 5.20
AC Grid Terminal Connector Inside

The steps to assemble AC grid terminal connector are listed as follows:

A) Strip the end of AC wire about 8mm. See figure 5.21 left.

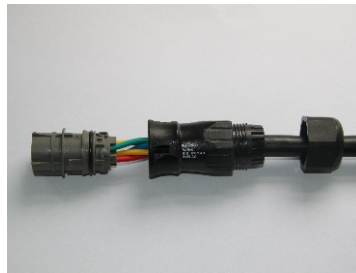
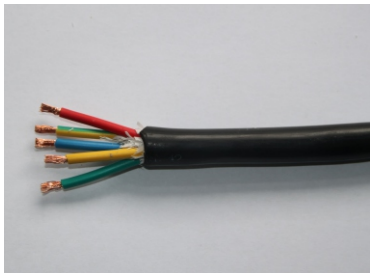

Figure 5.21 Connect Wires to the Grid Terminal

5. Installation

B) Insert the cable through the jacket and cap nut of connector, then insert the wires to the grid terminal and tighten the screws on the connector (see figure 5.22).

Please try to pull out the wire to make sure it is well connected.



Figure 5.22 Connected cable



Please fixed cable with PH1 cross screwdriver.

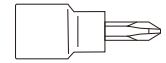

PH1 cross screwdriver

C) Assemble the connector and tighten up cap on the terminal. See Figure 5.21 right.

D) Connect AC grid terminal connector to the inverter, small click will confirm that connection is appropriate. (see figure 5.23)

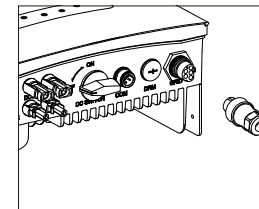

Figure 5.23 AC connector to inverter

5. Installation

5.3.4 Max. over current protection device (OCPD)

To protect the inverter's AC grid connection conductors, Solis recommends installing breakers that will protect against overcurrent. The following table defines OCPD ratings for the Solis 5-10kW three phase inverters.

Inverter	Rated voltage(V)	Rated output current (A)	Current for protection device (A)
Solis-3P5K-4G	400	7.2	20
Solis-3P6K-4G	400	8.7	20
Solis-3P8K-4G	400	11.5	20
Solis-3P9K-4G	400	13.0	32
Solis-3P10K-4G	400	14.4	32
Solis-3P5K-4G-LV	208/220/240	13.1	32

Table 5.2 Rating of grid OCPD

5.3.5 Inverter monitoring connection

The inverter can be monitored via Wi-Fi or GPRS. All Solis communication devices are optional (Figure 5.24). For connection instructions, please refer to the Solis Monitoring Device installation manuals.

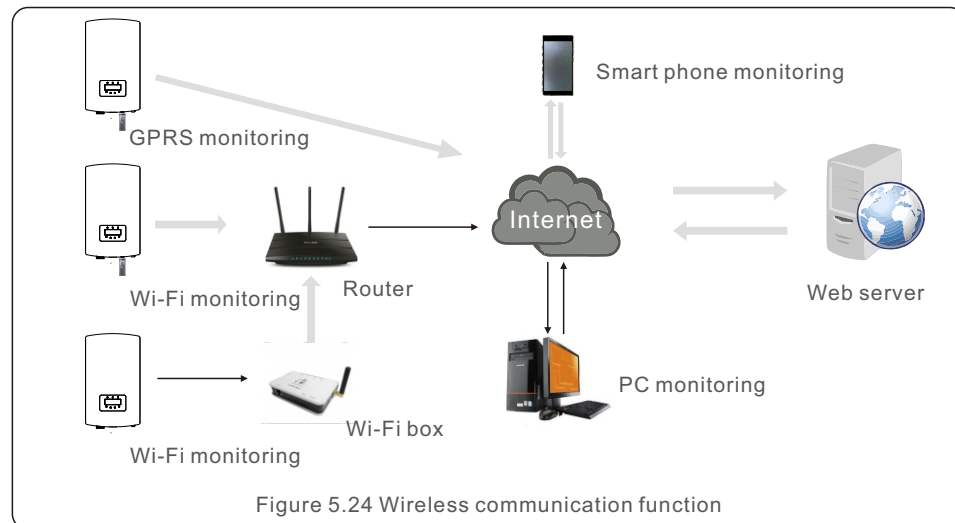

Figure 5.24 Wireless communication function

6. Start & Stop

6.1 Start the Inverter

To start up the Inverter, it is important that the following steps are strictly followed:

1. Switch the grid supply main Switch (AC) ON first.
2. Switch the DC switch ON. If the voltage of PV arrays are higher than start up voltage, the inverter will turn on. The red LED power will light.
3. When both the DC and the AC sides supply to the inverter, it will be ready to generate power. Initially, the inverter will check both its internal parameters and the parameters of the AC grid, to ensure that they are within the acceptable limits. At the same time, the green LED will flash and the LCD displays the information of INITIALIZING.
4. After 30-300 seconds (depending on local requirement), the inverter will start to generate power. The green LED will be on continually and the LCD displays GENERATING.



WARNING:

Do not touch the surface when the inverter is operating. It may be hot and cause burns.

6.2 Stop the Inverter

To stop the Inverter, the following steps must be strictly followed:

1. Turn off the ac switch.
2. Put the DC SWITCH on the inverter in the position of "OFF".
3. Remove the positive and negative dc lines and remove the ac lines.

7. Operation

In normal operation, LCD screen alternatively shows inverter power and operation status (see Figure 7.1). The screen can be scrolled manually by pressing the UP/DOWN keys. Pressing the ENTER key gives access to Main Menu.

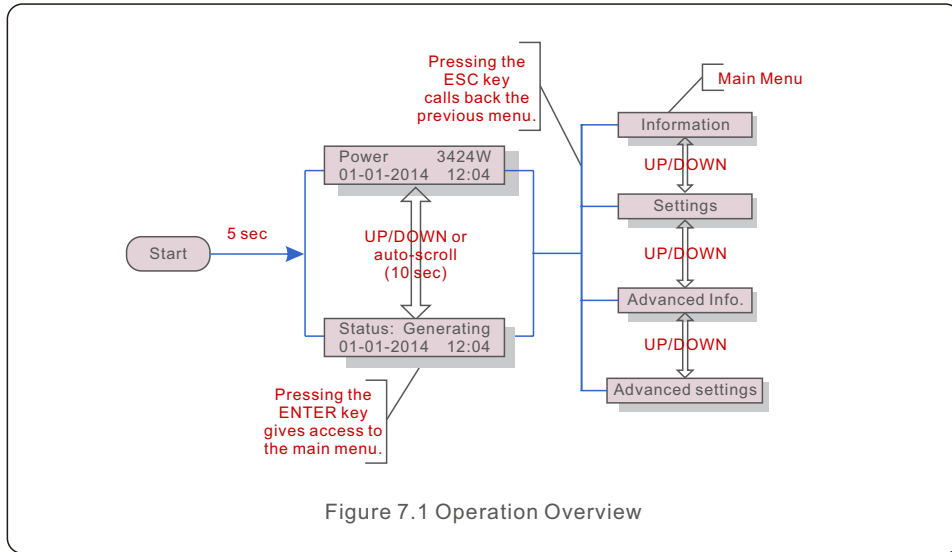

7.1 Main Menu

There are four submenus in the Main Menu (see Figure 7.1):

1. Information
2. Settings
3. Advanced Info.
4. Advanced Settings

7.2 Information

The Solis three Phase 4G Inverter main menu provides access to operational data and information. The information is displayed by selecting "Information" from the menu and then by scrolling up or down.

7. Operation

Display	Duration	Description
V_DC1 350.8V I_DC1 5.1A	10 sec	V_DC1: Shows input 01 voltage value. I_DC1: Shows input 01 current value.
V_DC2 350.8V I_DC2 5.1A	10 sec	V_DC2: Shows input 02 voltage value. I_DC2: Shows input 02 current value.
V_A 230.4V I_A 8.1A	10 sec	V_A: Shows the grid's voltage value. I_A: Shows the grid's current value.
V_C 230.4V I_C 8.1A	10 sec	V_C: Shows the grid's voltage value. I_C: Shows the grid's current value.
Status: Generating Power: 1488W	10 sec	Status: Shows instant status of the Inverter. Power: Shows instant output power value.
Grid Frequency F_Grid 50.06Hz	10 sec	F_Grid: Shows the grid's frequency value.
Total Energy 0258458 kwh	10 sec	Total generated energy value.
This Month: 0123kwh Last Month: 0123kwh	10 sec	This Month: Total energy generated this month. Last Month: Total energy generated last month.
Today: 15.1kwh Yesterday: 13.5kwh	10 sec	Today: Total energy generated today. Yesterday: Total energy generated yesterday.
Inverter SN 00000000000000	10 sec	Display series number of the inverter.

Table 7.1 Information list

7.2.1 Lock screen

Pressing the ESC key returns to the Main Menu. Pressing the ENTER key locks (Figure 7.2(a)) or unlocks (Figure 7.2 (b)) the screen.

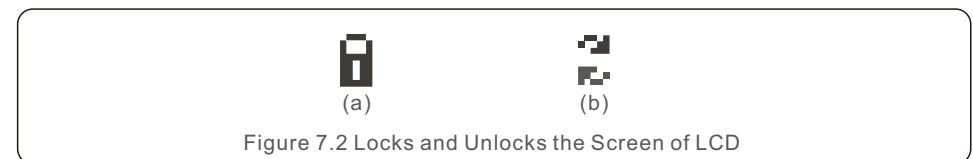

7. Operation

7.3 Settings

The following submenus are displayed when the Settings menu is selected:

- 1.Set Time
- 2.Set Address

7.3.1 Set Time

This function allows time and date setting. When this function is selected, the LCD will display a screen as shown in Figure 7.3.

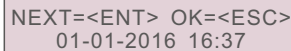

NEXT=<ENT> OK=<ESC>
01-01-2016 16:37

Figure 7.3 Set Time

Press the UP/DOWN keys to set time and data. Press the ENTER key to move from one digit to the next (from left to right). Press the ESC key to save the settings and return to the previous menu.

7.3.2 Set Address

This function is used to set the address when muti inverters are connected to three monitor. The address number can be assigned from "01"to "99"(see Figure 7.4). The default address number of Solis Three Phase Inverter is "01".



YES=<ENT> NO=<ESC>
Set Address: 01

Figure 7.4 Set Address

Press the UP/DOWN keys to set the address. Press the ENTER key to save the settings. Press the ESC key to cancel the change and return to the previous menu.

7.4 Advanced Info - Technicians Only



NOTE:

To access to this area is for fully qualified and accredited technicians only. Enter menu "Advanced Info." and "Advanced settings" (need password) .

7. Operation

Select "Advanced Info." from the Main Menu. The screen will require the password as below:



YES=<ENT> NO=<ESC>
Password:0000

Figure 7.5 Enter password

After enter the correct password the Main Menu will display a screen and be able to access to the following information.

- 1.Alarm Message
2. Running message
- 3.Version
4. Daily Energy
5. Monthly Energy
6. Yearly Energy
7. Daily Record
- 8.Communication Data

The screen can be scrolled manually by pressing the UP/DOWN keys. Pressing the ENTER key gives access to a submenu. Press the ESC key to return to the Main Menu.

7.4.1 Alarm Message

The display shows the 100 latest alarm messages (see Figure 7.6). Screens can be scrolled manually by pressing the UP/ DOWN keys. Press the ESC key to return to the previous menu.



Alarm001: OV-G-V
Time: 27-11 Data: 7171

Figure 7.6 Alarm Message

7.4.2 Running Message

This function is for maintainece person to get running message such as internal temperature, Standard No. 1,2,etc.

Screens can be scrolled manually by pressing the UP/DOWN keys.

7.4.3 Version

The screen shows the model version and the software version of the Inverter (see Figure 7.7).



Model: 08
Software Version: D20001

Figure 7.7 Model Version and Software Version

7. Operation

7.4.4 Daily Energy

The function is for checking the energy generation for selected day.

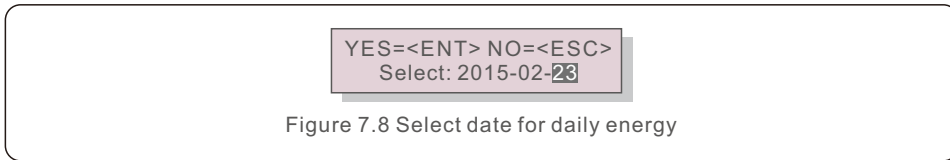

Figure 7.8 Select date for daily energy

Press DOWN key to move the cursor to day, month and year, press UP key to change the digit. Press Enter after the date is fixed.

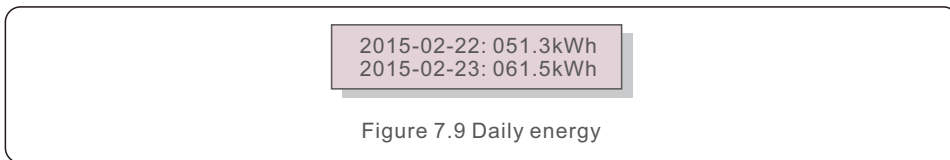

Figure 7.9 Daily energy

Press UP/DOWN key to move one date from another.

7.4.5 Monthly Energy and Yearly Energy

The two functions are for checking the energy generation for selected month and Year.

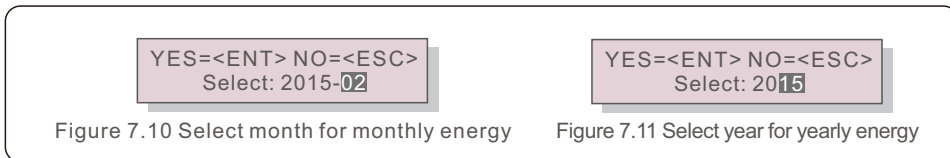

Figure 7.10 Select month for monthly energy

Figure 7.11 Select year for yearly energy

Press DOWN key to move the cursor, press UP key to change the digit. Press Enter after the month/year is fixed.

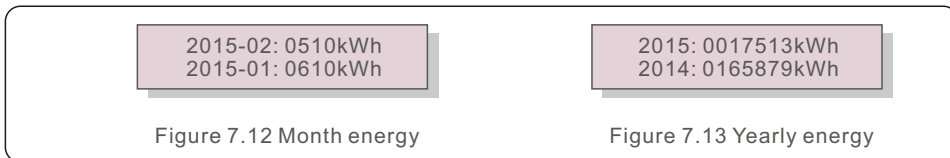

Figure 7.12 Month energy

Figure 7.13 Yearly energy

Press UP/DOWN key to move one date from another.

7.4.6 Daily record

The screen shows history of changing settings. Only for maintenance personnel.

7. Operation

7.4.7 Communication Data

The screen shows the internal data of the Inverter (see Figure 7.14), which is for service technicians only.

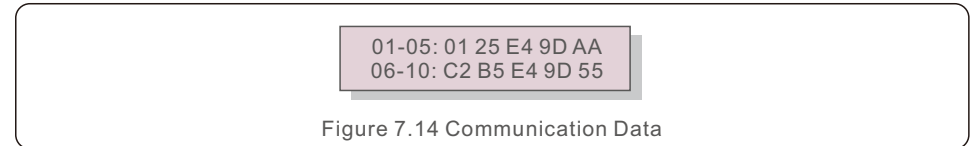
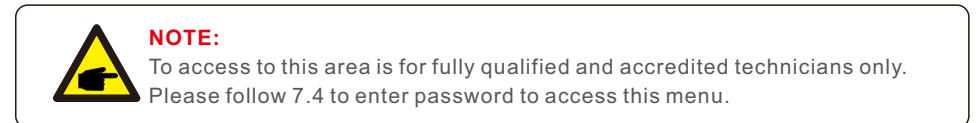

Figure 7.14 Communication Data

7.5 Advanced Settings - Technicians Only



Select Advanced Settings from the Main Menu to access the following options:

- 1. Select Standard
- 2. Grid ON/OFF
- 3. Clear Energy
- 4. New Password
- 5. Power Control
- 6. Calibrate Energy
- 7. STD. Mode Settings

7.5.1 Selecting Standard

This function is used to select the grid's reference standard (see Figure 7.15).

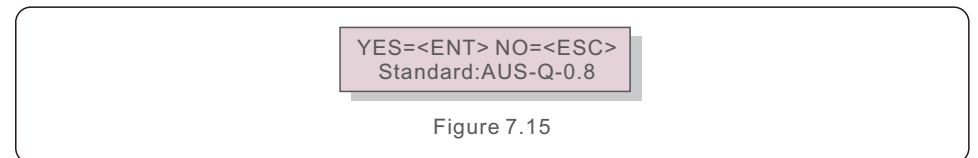
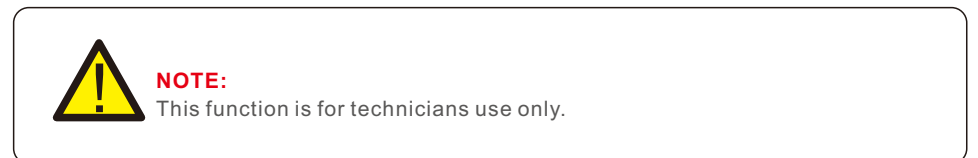

Figure 7.15

Press the UP/DOWN keys to select the standard (AS4777, VDE4105, VDE0126, UL-240V-A, UL-208V-A, UL-240V, UL-208V, MEX-CFE, G83/2 (for 1-3.6kW models), G59/3 (for 4-5kW models), EN50438 DK, EN50438 IE, EN50438 NL and "User-Def" function). Press the ENTER key to confirm the setting. Press the ESC key to cancel changes and returns to previous menu.



7. Operation

Selecting the "User-Def" menu will access to the following submenu (see Figure 7.16),

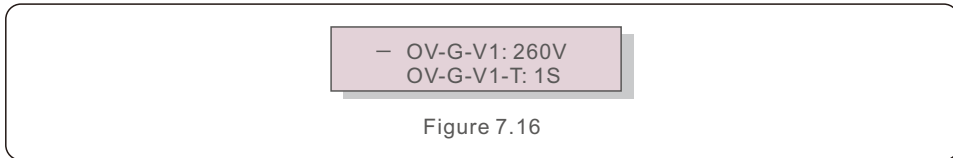

Figure 7.16



NOTE:

The " User-Def" function can be only used by the service engineer and must be allowed by the local energy supplier.

Below is the setting range for "User-Def". Using this function, the limits can be changed manually.

OV-G-V1: 220---290V	OV-G-F1: 50.2-53Hz(60.2-64Hz)
OV-G-V1-T: 0.1---9S	OV-G-F1-T: 0.1---9S
OV-G-V2: 220---290V	OV-G-F2: 50.2-53Hz(60.2-64Hz)
OV-G-V2-T: 0.1---1S	OV-G-F2-T: 0.1---9S
UN-G-V1: 90---210V	UN-G-F1: 47-49.5Hz(56-59.8Hz)
UN-G-V1-T: 0.1---9S	UN-G-F1-T: 0.1---9S
UN-G-V2: 90---210V	UN-G-F2: 47-49Hz(56-59.8Hz)
UN-G-V2-T: 0.1---1S	UN-G-F2-T: 0.1---9S
Startup-T:10---600S	
Restore-T:10---600S	

Press the UP/DOWN keys to scroll through items. Press the ENTER key to edit the highlighted item. Press the UP/DOWN keys again to change the setting. Press the ENTER key to save the setting. Press the ESC key to cancel changes and returns to the previous menu.

7.5.2 Grid ON/OFF

This function is used to start up or stop the power generation of Solis Three Phase Inverter (see Figure 7.17).

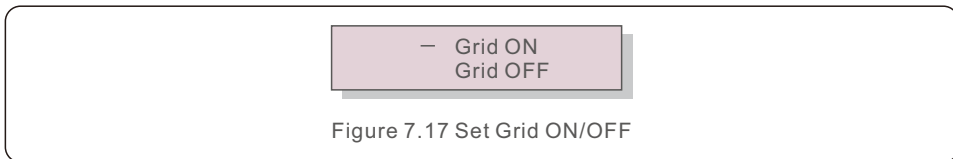

Figure 7.17 Set Grid ON/OFF

Screens can be scrolled manually by pressing the UP/DOWN keys. Press the ENTER key to save the setting. Press the ESC key to return to the previous menu.

7. Operation

7.5.3 Clear Energy

Clear Energy can reset the history yield of inverter



These two functions are applicable by maintenance personnel only, wrong operation will prevent the inverter from working properly.

7.5.4 New Password

This function is used to set the new password for menu "Advanced info." and "Advanced information" (see Figure 7.18).

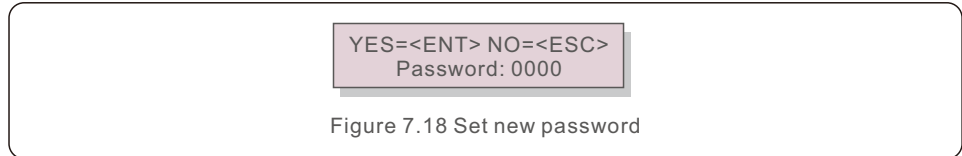

Figure 7.18 Set new password

Enter the right password before set new password. Press the DOWN key to move the cursor, Press the UP key to revise the value. Press the ENTER key to execute the setting. Press the ESC key to return to the previous menu.

7.5.5 Power control

Active and reactive power can be set through power setting button.

There are 5 item for this sub menu:

1. Set output power
2. Set Reactive Power
3. Out_P With Restore
4. Rea_P With Restore
5. Select PF Curve



This function is applicable by maintenance personnel only, wrong operation will prevent the inverter from reaching maximum power.

7.5.6 Calibrate Energy

Maintenance or replacement could clear or cause a different value of total energy. Use this function could allow user to revise the value of total energy to the same value as before. If the monitoring website is used the data will be synchronous with this setting automatically. (see Figure 7.19).

7. Operation

YES=<ENT> NO=<ESC>
Energy:0000000kWh

Figure 7.19 Calibrate energy

Press the DOWN key to move the cursor, Press the UP key to revise the value. Press the ENTER key to execute the setting. Press the ESC key to return to the previous menu.

7.5.7 STD setting

Solis 4G inverter could set different work mode to work with different grid requirement. There are 4 items under STD mode setting.

- 1. Working Mode Set 2. Power Rate Limit 3. Freq Derate Set 4. 10mins Voltage Set 5. Initial Settings.

There are 6 items in working mode submenu.

- 1. NULL, Volt-watt 2. Volt-var 3. Fixed-PF 4. Reac-power 5. Power-PF

There are 2 items in power rate limit submenu.

- 1. Power Rate: 0-100% 2. RateP_Sts-US: stop/run

There are 3 items in Freq Derate Set submenu.

- 1. over Freq 2. under Freq 3. Derate mode.

There is 1 item in 10mins voltage set submenu.

- 1. 10mins voltage : 244-258V.

There are 5 items in initial setting submenu.

- 1. Work mode default 2. Power rate default 3. Fre Derate Default 4. 10mVvoltage Default 5. DRM ON/OFF

8. Maintenance

Solis Three Phase Inverter does not require any regular maintenance. However, cleaning the dust on heat-sink will help the inverter to dissipate the heat and increase its life time. The dust can be removed with a soft brush.



CAUTION:

Do not touch the inverter's surface when it is operating. Some parts of the inverter may be hot and cause burns. Turn off the inverter (refer to Section 6.2) and wait for a cool-down period before any maintenance or cleaning operation.

The LCD and the LED status indicator lights can be cleaned with a damp cloth if they are too dirty to be read.



NOTE:

Never use any solvents, abrasives or corrosive materials to clean the inverter.

9. Troubleshooting

The inverter is designed in accordance with the most important international grid-tied standards and safety and electromagnetic compatibility requirements. Before delivering to the customer, the inverter has been subjected to several tests to ensure its optimal operation and reliability.

In case of failure, the LCD screen will display an alarm message. In this case, the inverter may stop feeding into the grid. The failure descriptions and their corresponding alarm messages are listed in Table 9.1:

9. Trouble Shooting

Alarm Message	Failure description	Solution
No power	Inverter no power on LCD	1.Check PV input connections 2.Check DC input voltage (single phase >120V, three phase >350V) 3.Check if PV+/- is reversed
LCD show initializing all the time	Can not start-up	1.Check if the connector on main board or power board are fixed. 2.Check if the DSP connector to power board are fixed.
OV-G-V01/02/03/04	Over grid voltage	1.Resistant of AC cable is too high. Change bigger size grid cable 2.Adjust the protection limit if it's allowed by electrical company.
UN-G-V01/02	Under grid voltage	1. Use user define function to adjust the protection limit if it's allowed by electrical company.
OV-G-F01/02	Over grid frequency	
UN-G-F01/02	Under grid frequency	
G-IMP	High grid impedance	
NO-GRID	No grid voltage	1.Check connections and grid switch. 2.Check the grid voltage inside inverter terminal.
OV-DC01/02/03/04	Over DC voltage	1.Reduce the module number in series
OV-BUS	Over DC bus voltage	1.Check inverter inductor connection 2.Check driver connection
UN-BUS01/02	Under DC bus voltage	
GRID-INTF01/02	Grid interference	1.Restart inverter 2.Change power board
OV-G-I	Over grid current	
IGBT-OV-I	Over IGBT current	
DC-INTF OV-DCA-I	DC input overcurrent	1.Restart inverter 2.Identify and remove the string to the fault MPPT 2.Change power board
IGFOL-F	Grid current tracking fail	1.Restart inverter or contact installer.
IG-AD	Grid current sampling fail	
OV-TEM	Over Temperature	1.Check inverter surrounding ventilation. 2.Check if there's sunshine direct on inverter in hot weather.
INI-FAULT	Initialization system fault	1.Restart inverter or contact installer.
DSP-B-FAULT	Comm. failure between main and slave DSP	
12Power-FAULT	12V power supply fault	

9. Trouble Shooting

Alarm Message	Failure description	Solution
PV ISO-PRO 01/02	PV isolation protection	1.Remove all DC input, reconnect and restart inverter one by one. 2.Identify which string cause the fault and check the isolation of the string.
ILeak-PRO 01/02/03/04	Leakage current protection	1.Check AC and DC connection 2.Check inverter inside cable connection.
RelayChk-FAIL	Relay check fail	1.Restart inverter or contact installer.
DCinj-FAULT	High DC injection current	
AFCI self-detection (model with AFCI module)	AFCI module self-detect fault	1.Restart inverter or connect technician.
Arcing protection (model with AFCI module)	Detect arc in DC circuit	1. Check inverter connection whether arc exists and restart inverter.

Table 9.1 Fault message and description



NOTE:

If the inverter displays any alarm message as listed in Table 9.1; please turn off the inverter (refer to Section 5.2 to stop your inverter) and wait for 5 minutes before restarting it (refer to Section 5.1 to start your inverter). If the failure persists, please contact your local distributor or the service center. Please keep ready with you the following information before contacting us.

1. Serial number of Solis Three Phase Inverter;
2. The distributor/dealer of Solis Three Phase Inverter (if available);
3. Installation date.
4. The description of problem (i.e. the alarm message displayed on the LCD and the status of the LED status indicator lights. Other readings obtained from the Information submenu (refer to Section 6.2) will also be helpful.);
5. The PV array configuration (e.g. number of panels, capacity of panels, number of strings, etc.);
6. Your contact details.

10. Specifications

Model	Solis-3P5K-4G
Max. DC input power (Watts)	6000
Max. DC input voltage (Volts)	1000
Rated DC voltage (Volts)	600
Start-up voltage (Volts)	180
MPPT voltage range (Volts)	160...850
Max. input current (Amps)	11+11
Max short circuit input current (Amps)	17.2+17.2
MPPT number/Max input strings number	2/2
Rated output power (Watts)	5000
Max. output power (Watts)	5500
Max. apparent output power (VA)	5500
Rated grid voltage (Volts)	3/N/PE~400
Grid voltage range (Volts)	313...470
Rated output current (Amps)	7.2
Power Factor (at rated output power)	0.8leading~0.8lagging
THDi (at rated output power)	<1.5%
Rated grid frequency (Hertz)	50/60
Operating frequency range (Hertz)	47...52 or 57...62
Max. efficiency	98.3%
EU efficiency	97.8%
MPPT efficiency	>99.5%
Dimensions	310W*538H*158D (mm)
Weight	13.6kg
Topology	Transformerless
Operating ambient temperature range	-25°C. . . 60°C
Ingress protection	IP65
Noise emission (typical)	<30 dBA
Cooling concept	Natural convection
Max.operation altitude	4000m
Designed lifetime	>20 years
Grid connection standard	EN50438, G83/2, AS4777.2:2015, VDE0126-1-1, IEC61727, VDE N4105
Operating surroundings humidity	0...100% Condensing
Connention	Mc4 connector and Ip67 rated plug
Display	LCD, 2×20 Z.
Communication connections	4 pins RS485 connector
Monitoring	WiFi or GPRS
Warranty Terms	5 Years STD (Extendable to 20 Years)

10. Specifications

Model	Solis-3P6K-4G
Max. DC input power (Watts)	7200
Max. DC input voltage (Volts)	1000
Rated DC voltage (Volts)	600
Start-up voltage (Volts)	180
MPPT voltage range (Volts)	160...850
Max. input current (Amps)	11+11
Max short circuit input current (Amps)	17.2+17.2
MPPT number/Max input strings number	2/2
Rated output power (Watts)	6000
Max. output power (Watts)	6600
Max. apparent output power (VA)	6600
Rated grid voltage (Volts)	3/N/PE~400
Grid voltage range (Volts)	313...470
Rated output current (Amps)	8.7
Power Factor (at rated output power)	0.8leading~0.8lagging
THDi (at rated output power)	<1.5%
Rated grid frequency (Hertz)	50/60
Operating frequency range (Hertz)	47...52 or 57...62
Max. efficiency	98.3%
EU efficiency	97.8%
MPPT efficiency	>99.5%
Dimensions	310W*538H*158D (mm)
Weight	13.6kg
Topology	Transformerless
Operating ambient temperature range	-25°C. . . 60°C
Ingress protection	IP65
Noise emission (typical)	<30 dBA
Cooling concept	Natural convection
Max.operation altitude	4000m
Designed lifetime	>20 years
Grid connection standard	EN50438, G83/2, AS4777.2:2015, VDE0126-1-1, IEC61727, VDE N4105
Operating surroundings humidity	0...100% Condensing
Connention	Mc4 connector and Ip67 rated plug
Display	LCD, 2×20 Z.
Communication connections	4 pins RS485 connector
Monitoring	WiFi or GPRS
Warranty Terms	5 Years STD (Extendable to 20 Years)

10. Specifications

Model	Solis-3P8K-4G
Max. DC input power (Watts)	9600
Max. DC input voltage (Volts)	1000
Rated DC voltage (Volts)	600
Start-up voltage (Volts)	180
MPPT voltage range (Volts)	160...850
Max. input current (Amps)	11+11
Max short circuit input current (Amps)	17.2+17.2
MPPT number/Max input strings number	2/2
Rated output power (Watts)	8000
Max. output power (Watts)	8800
Max. apparent output power (VA)	8800
Rated grid voltage (Volts)	3/N/PE~400
Grid voltage range (Volts)	313...470
Rated output current (Amps)	11.5
Power Factor (at rated output power)	0.8leading~0.8lagging
THDi (at rated output power)	<1.5%
Rated grid frequency (Hertz)	50/60
Operating frequency range (Hertz)	47...52 or 57...62
Max. efficiency	98.7%
EU efficiency	98.1%
MPPT efficiency	>99.5%
Dimensions	310W*538H*158D (mm)
Weight	14.1kg
Topology	Transformerless
Operating ambient temperature range	-25°C. . . 60°C
Ingress protection	IP65
Noise emission (typical)	<30 dBA
Cooling concept	Natural convection
Max.operation altitude	4000m
Designed lifetime	>20 years
Grid connection standard	EN50438, G83/2, AS4777.2:2015, VDE0126-1-1, IEC61727, VDE N4105
Operating surroundings humidity	0...100% Condensing
Connention	Mc4 connector and Ip67 rated plug
Display	LCD, 2×20 Z.
Communication connections	4 pins RS485 connector
Monitoring	WiFi or GPRS
Warranty Terms	5 Years STD (Extendable to 20 Years)

10. Specifications

Model	Solis-3P9K-4G
Max. DC input power (Watts)	10800
Max. DC input voltage (Volts)	1000
Rated DC voltage (Volts)	600
Start-up voltage (Volts)	180
MPPT voltage range (Volts)	160...850
Max. input current (Amps)	11+11
Max short circuit input current (Amps)	17.2+17.2
MPPT number/Max input strings number	2/2
Rated output power (Watts)	9000
Max. output power (Watts)	9900
Max. apparent output power (VA)	9900
Rated grid voltage (Volts)	3/N/PE~400
Grid voltage range (Volts)	313...470
Rated output current (Amps)	13
Power Factor (at rated output power)	0.8leading~0.8lagging
THDi (at rated output power)	<1.5%
Rated grid frequency (Hertz)	50/60
Operating frequency range (Hertz)	47...52 or 57...62
Max. efficiency	98.7%
EU efficiency	98.1%
MPPT efficiency	>99.5%
Dimensions	310W*538H*158D (mm)
Weight	14.1kg
Topology	Transformerless
Operating ambient temperature range	-25°C. . . 60°C
Ingress protection	IP65
Noise emission (typical)	<30 dBA
Cooling concept	Natural convection
Max.operation altitude	4000m
Designed lifetime	>20 years
Grid connection standard	EN50438, G83/2, AS4777.2:2015, VDE0126-1-1, IEC61727, VDE N4105
Operating surroundings humidity	0...100% Condensing
Connention	Mc4 connector and Ip67 rated plug
Display	LCD, 2×20 Z.
Communication connections	4 pins RS485 connector
Monitoring	WiFi or GPRS
Warranty Terms	5 Years STD (Extendable to 20 Years)

10. Specifications

Model	Solis-3P10K-4G
Max. DC input power (Watts)	12000
Max. DC input voltage (Volts)	1000
Rated DC voltage (Volts)	600
Start-up voltage (Volts)	180
MPPT voltage range (Volts)	160...850
Max. input current (Amps)	11+11
Max short circuit input current (Amps)	17.2+17.2
MPPT number/Max input strings number	2/2
Rated output power (Watts)	10000
Max. output power (Watts)	11000
Max. apparent output power (VA)	11000
Rated grid voltage (Volts)	3/N/PE~400
Grid voltage range (Volts)	313...470
Rated output current (Amps)	11.5
Power Factor (at rated output power)	0.8leading~0.8lagging
THDi (at rated output power)	<1.5%
Rated grid frequency (Hertz)	50/60
Operating frequency range (Hertz)	47...52 or 57...62
Max. efficiency	98.7%
EU efficiency	98.1%
MPPT efficiency	>99.5%
Dimensions	310W*538H*158D (mm)
Weight	14.1kg
Topology	Transformerless
Operating ambient temperature range	-25°C. . . 60°C
Ingress protection	IP65
Noise emission (typical)	<30 dBA
Cooling concept	Natural convection
Max.operation altitude	4000m
Designed lifetime	>20 years
Grid connection standard	EN50438, G83/2, AS4777.2:2015, VDE0126-1-1, IEC61727, VDE N4105
Operating surroundings humidity	0...100% Condensing
Connention	Mc4 connector and Ip67 rated plug
Display	LCD, 2×20 Z.
Communication connections	4 pins RS485 connector
Monitoring	WiFi or GPRS
Warranty Terms	5 Years STD (Extendable to 20 Years)

10. Specifications

Model	Solis-3P5K-4G-LV
Max. DC input power (Watts)	6000
Max. DC input voltage (Volts)	600
Rated DC voltage (Volts)	330
Start-up voltage (Volts)	180
MPPT voltage range (Volts)	160...500
Max. input current (Amps)	11+11
Max short circuit input current (Amps)	17.2+17.2
MPPT number/Max input strings number	2/2
Rated output power (Watts)	5000
Max. output power (Watts)	5500
Max. apparent output power (VA)	5500
Rated grid voltage (Volts)	3/PE~208/220/240
Grid voltage range (Volts)	180...270
Rated output current (Amps)	13.1
Power Factor (at rated output power)	0.8leading~0.8lagging
THDi (at rated output power)	<1.5%
Rated grid frequency (Hertz)	50/60
Operating frequency range (Hertz)	47...52 or 57...62
Max. efficiency	98.0%
EU efficiency	97.5%
MPPT efficiency	>99.5%
Dimensions	310W*538H*158D (mm)
Weight	14.1kg
Topology	Transformerless
Operating ambient temperature range	-25°C. . . 60°C
Ingress protection	IP65
Noise emission (typical)	<30 dBA
Cooling concept	Natural convection
Max.operation altitude	4000m
Designed lifetime	>20 years
Grid connection standard	EN50438, G83/2, AS4777.2:2015, VDE0126-1-1, IEC61727, VDE N4105
Operating surroundings humidity	0...100% Condensing
Connention	Mc4 connector and Ip67 rated plug
Display	LCD, 2×20 Z.
Communication connections	4 pins RS485 connector
Monitoring	WiFi or GPRS
Warranty Terms	5 Years STD (Extendable to 20 Years)